

RESOLUTION NO. 2022- 162

A RESOLUTION AUTHORIZING THE PURCHASE OF CONSTRUCTION EQUIPMENT FROM GT MID ATLANTIC, VINELAND, NJ, IN AN AGGREGATE AMOUNT NOT TO EXCEED \$924,666.00, PURSUANT TO A NATIONAL COOPERATIVE CONTRACT AGREEMENT WITH SOURCEWELL, CONTRACT 032119 CNH.

WHEREAS, the City of Vineland is in need of various types of construction equipment; and

WHEREAS, the City of Vineland is a member of a National Cooperative Purchasing Agreement known as Sourcewell under member number 19409; and, Sourcewell is a national cooperative contract organization; and

WHEREAS, Sourcewell, National Cooperative Purchasing Program has acted as lead agency and awarded Contract 032119 CNH, Construction Equipment and Services. Specific information regarding the contract may be found on the Sourcewell website at www.sourcewell-mn.gov; and

WHEREAS, N.J.S.A. 52:34-6.2 permits the City of Vineland to purchase the below equipment using the offered National Cooperative Contract without public bidding, subject to the submittal and acceptance of certain documentation by GT Mid Atlantic; and

WHEREAS, the City of Vineland intends under Sourcewell, under the Category: Construction Equipment and Services, Contract 032119 CNH, to purchase from GT Mid Atlantic, Vineland, NJ, the following equipment for the designated City of Vineland Departments and Divisions, in the not-to-exceed amounts, as listed in the Quotations dated March 30, April 6, and April 7, 2022, made available through Sourcewell:

Mason Crew/Business Administration:

One Mini Excavator CX57C, not to exceed \$84,406.00

Mason Crew/Business Administration:

One Case Model TV450B Compact Track Loader, not to exceed \$88,831.00

Department of Public Works:

Two (2) Case Wheel Loaders, Model 821G, not to exceed \$620,918.00

Department of Public Works:

One Case 580SNWT Backhoe, not to exceed \$130,511.00

WHEREAS, the Department and Division Directors and Supervisors and the Qualified Purchasing Agent, with the concurrence of the Business Administrator, recommend the use of the National Cooperative Pricing through Sourcewell for this procurement; and

WHEREAS, the City of Vineland Purchasing Agent has determined that the use of the offered National Cooperative Pricing Agreement will result in cost savings after all factors, including charges for service, material and delivery have been considered and has verified that such equipment is/are not available through State Contract awarded by the Division of Purchase and Property in the New Jersey Department of the Treasury, pursuant to N.J.S.A. 40A:11-12; and

WHEREAS, the availability of funds for said purchase to be awarded herein has been certified by the Chief Financial Officer; and

WHEREAS, the City of Vineland has certified that this meets the statute and regulations governing the award of said contracts;

NOW, THEREFORE, BE IT RESOLVED BY THE COUNCIL OF THE CITY OF VINELAND, that the Purchasing Agent is authorized to prepare purchase orders to procure the equipment listed above, for an aggregate price not to exceed \$924,666.00.

BE IT FURTHER RESOLVED that the purchase order(s) shall contain a requirement that “the vendor shall maintain all documentation related to products, transactions or services under this contract for a period of five years from the date of final payment. Such records shall be made available to the New Jersey Office of the State Comptroller upon request.”

Adopted:

President of Council

ATTEST:

City Clerk

REQUEST FOR RESOLUTION
FOR COOPERATIVE CONTRACT AWARDS
UNDER 40A:11-12, N.J.A.C. 5:34-7.29 & LFN 2012-10
(REQUIRED FOR PURCHASES OVER \$17,500.00)



4-7-22
(DATE)

1. Goods or Services (detailed description): MINI EXCAVATOR CX57C
FOR MASON CREW / BA

2. Amount to be Awarded: \$ 84,406.00

- Encumber Total Award
 Encumber by Supplemental Release

3. Budgeted: By Ordinance No. _____
Or Grant: Title & Year _____

4. **Account Number to be Charged: C-04-00-000-2223-78002

5. Contract Period (if applicable): _____

6. Date to be Awarded: _____

7. Recommended Vendor and Address: GT mid ATLANTIC
551 N HARDING HWY
VINELAND NJ 08360

8. Justification for Vendor Recommendation: (attach add'l information for Council review)

Type of Contract: State National Regional County

Vendor's Cooperative Contract # Sourcewell H5530 D32119 CNH

9. Evaluation Performed by: Don Schatz

10. Approved by: [Signature]

11. Attachments:
 Awarding Proposal
 Other: _____

- Send copies to:
Purchasing Department
Business Administration

**If more than one account #, provide break down



Mid Atlantic

For Everything Under Construction

SALES ORDER

VINELAND
 551 N. HARDING HWY
 VINELAND, NJ 08360
 856-697-1414

FREEHOLD
 212 MONMOUTH RD.
 FREEHOLD, NJ 07728
 732-780-4600

TOTOWA
 200 BOMONT PLACE
 TOTOWA, NJ 07512
 973-785-4900

S
O
L
D

T
O

City of Vineland
640 Wood Street
Vineland, NJ 08360

TERMS: <input checked="" type="checkbox"/> CASH <input type="checkbox"/> FINANCE		
FINANCE CO:	RATE	TERM
		Net 30
SPECIAL FINANCING TERMS: Municipal		
REQ. DELIVERY DATE:	<input type="checkbox"/> CUSTOMER PICKUP	SOLD BY
	<input checked="" type="checkbox"/> DEALER DELIVERY	Bob T

Date April 6 2022	Account Number Sourcewell # 115530	County Cumberland	Contact Person Don	Phone	Customer P.O. #
----------------------	--	----------------------	-----------------------	-------	-----------------

QTY	N- NEW U- USED R- RENTAL	MANUFACTURER	MODEL	SERIAL NUMBER	STOCK NO.	PRICE
1	New	Case	CX57C	TBD	TBd	\$100,942.00
		Sourcewell Contract #032119 CNH		25% DISCOUNT		(\$25,236.00)
		Dealer Installed		Coupler/ thumb/buckets		\$8,700.00

<SPECIAL INSTRUCTIONS>
 NEW CASE CX57C Compact Excavator
 Includes: Standard Blade, LED Light Pkg, 2way Prop Hydraulics, Manual Coupler, 24" & 18" Buckets, Hydraulic Thumb

TRADE-INS Purchaser hereby bargains, sells and conveys unto Seller the following described Trade-In Equipment and warranties and certifies it to be free and clear of liens, encumbrance, and security interests except to the extent below.					1. SALE PRICE	\$84,406.00
					2. FREIGHT	\$0.00
YEAR	MAKE	MODEL	SERIAL NUMBER	TRADE AMOUNT	3. SUBTOTAL	\$84,406.00
				\$0.00	4. LESS TRADE	\$0.00
					5. RENTS PAID	
OUTSTANDING LOAN WITH		ACCOUNT NUMBER		TOTAL TRADE (LINE 4)	6. ADJUSTED PRICE	\$84,406.00
				\$0.00	7. SALES TAX 0.000%	\$0.00
				OUTSTANDING BAL. OWED (LINE 12)		\$0.00
					8. FED EXCISE TAX	
					9. DOC. FEES	\$0.00
					9. TOTAL COST	\$84,406.00
					10. CASH DOWN PAYMENT	
					11. BALANCE DUE (PURCHASE)	\$84,406.00
					12. OUTSTANDING BAL. OF TRADE	\$0.00
					13. TOTAL UNPAID BALANCE	\$84,406.00

CASE PRO CARE: _____

WARRANTIES:

NEW (mfg) _____ **USED-AS IS: No warranty expressed or implied**

OTHER: Terms & Conditions

"ALL WARRANTIES, IF ANY BY A MANUFACTURER OR SUPPLIER OTHER THAN THE DEALER ARE THEIR WARRANTIES, NOT THE DEALERS, AND ONLY SUCH MANUFACTURER OR OTHER SUPPLIER SHALL BE LIABLE FOR PERFORMANCE UNDER SUCH WARRANTIES, UNLESS DEALER FURNISHES BUYER WITH A SEPARATE WRITTEN OR SERVICE CONTRACT MADE BY DEALER ON ITS OWN BEHALF. DEALER HEREBY DISCLAIMS ALL WARRANTIES, EXPRESSED OR IMPLIED, INCLUDING ANY IMPLIED WARRANTIES OF MERCHANTABILITY OR FITNESS FOR PARTICULAR PURPOSE ON ALL GOODS AND SERVICES SOLD BY DEALER AND ON ALL USED PRODUCTS WHICH ARE HEREBY SOLD "AS IS- NOT EXPRESSLY WARRANTIES OR GUARANTEED". ALL WARRANTY REPAIRS MADE UNDER THIS AGREEMENT WILL BE MADE AT THE GROFF TRACTOR NEW JERSEY, LLC SERVICE FACILITY. THE CUSTOMER IS RESPONSIBLE FOR ALL HAULING CHARGES TO AND FROM THE GROFF FACILITY.

1. Read this contract before you sign it.
2. You are entitled to and exact and completely filled in copy of this contract when you sign it. Keep it to protect your legal rights.
3. Purchaser acknowledges receipt of a fully completed copy of this contract and Purchaser waives notice of the acceptance or rejection of this order by the seller.
4. The additional terms and conditions set forth on the reverse side are a part of this contract and are incorporated herein by reference.
5. Seller retains a security interest in the purchased goods until the price is fully paid.

Accepted for GROFF TRACTOR MID ATLANTIC, LLC Purchased by: _____
 BY: _____ X: _____
 Groff Tractor NJ Signature Title Date Purchaser Signature Title Date

**Groff Tractor Mid Atlantic, LLC
Terms and Conditions**

1. PRICES: All Prices quoted herein are exclusive on and City, State or Federal taxes on manufacture, sales, use and the like. Whenever applicable, the buyer shall be solely responsible for payment thereof.

2. PAYMENT: Payments shall become due in accordance with the terms hereof. Finance charges are subject to rate approval by financial institutions. The terms of sale are subject to credit approval and seller may, at any time prior to delivery, modify the terms of payment originally specified to assure prompt payment for the equipment ordered.

3. SECURITY INTEREST: Seller shall retain a security interest in the equipment delivered hereunder until the total selling price, including taxes, delivery and other charges, is paid in full by buyer. Buyer agrees to sign and deliver to seller any additional security agreement required by seller. Buyer hereby appoints seller as buyer's agent to sign and cause to be filed on behalf of buyer any and all financing statements deemed necessary by seller to perfect the security interest granted by buyer to seller hereunder.

4. WARRANTY: Seller warrants each new product within the time period or hourly limitation established by the manufacturer thereof. Seller's sole obligation under this warranty shall be limited to repairing, replacing or allowing credit for, at seller's option, any part or component which under normal and proper use and maintenance proves defective in material or workmanship.

THIS WARRANTY IS IN LIEU OF ALL OTHER WARRANTIES, EXPRESSED OR IMPLIED AND THERE IS NO IMPLIED WARRANTY OF MERCHANTABILITY AND FITNESS FOR A PARTICULAR PURPOSE WHICH EXCEED THE AFORESTATED OBLIGATION ARE HEREBY DISCLAIMED BY SELLER AND EXCLUDED FROM THIS AGREEMENT, UNLESS OTHERWISE EXPRESSLY STATED ON THE FACE OF THIS FORM. USED PRODUCTS ARE SOLD ON AN "AS IS" BASIS AND THERE IS NO IMPLIED WARRANTY OR MERCHANTABILITY OR OF FITNESS FOR A PARTICULAR PURPOSE, UNLESS OTHERWISE EXPRESSLY STATED ON THE FACE OF THIS FORM.

FURTHER, THERE ARE NO ORAL OR WRITTEN PROMISES, TERMS, CONDITIONS, REPRESENTATIVES OF QUALITY OR FITNESS FOR ANY PURPOSE OR WARRANTIES, EXPRESSED OR IMPLIED, CONCERNING THESE PRODUCTS, OTHER THAN THOSE CONTAINED HEREIN IN WRITING, IF ANY.

BUYER AGREES TO INDEMNIFY AND HOLD TO SELLER HARMLESS FROM AND AGAINST ALL LIABILITY AND EXPENSES BASED UPON DAMAGE TO PROPERTY OR INJURY TO, OR DEATH OF, ANY PERSON ARISING OUT OF OR ATTRIBUTABLE TO THE USE OF SAID MACHINERY.

5. DEFAULT AND REPOSESSION: If buyer shall default in the performance of any of the terms, covenants and conditions of this Agreement, seller may declare the full amount due and payable without notice or demand and may repossess the equipment. Buyer agrees to pay attorney's fees in the amount of twenty percent (20%) of the amount due and payable, together with any other expenses incurred. Buyer shall be responsible for any expenses incurred by seller or its agents repossessing any item of equipment.

6. DELAYS: Seller may not be liable for loss or damage due to delay in delivery, resulting from any cause beyond seller's reasonable control including, but not limited to, acts of God, acts of omissions of the buyer, acts of civil or military authority, fires, strikes, factory shutdowns or alterations, embargos, war, riot or delay in transportation.

7. INSURANCE: The buyer shall at his own expense, but in the name for and in the benefit of the seller, insure said equipment against loss that may occur or be caused by fire, flood, explosion, theft or otherwise and liability of any and every kind until the selling price is paid in full by the buyer.

8. CANCELLATION: Buyer may cancel its order, reduce quantities, revise specifications or extend schedules only by mutual agreement as to reasonable and proper cancellation charges which shall take into account expenses already incurred and commitments made by the seller against any loss resulting there from.

INITIALS



ENGINE

Model	Yanmar 4TNV98C
Emissions Certification	Tier 4 Final
Fuel	Diesel
Cylinders	4
Displacement	203 in ³ (3 319 cc)
Fuel injection	Electronic common rail
Gross horsepower – SAE J1995 @ 2400 RPM:	66.9 hp (49.9 kW)
Net horsepower – SAE J1349 @ 2400 RPM:	65.1 hp (48.5 kW)
Maximum Engine Torque @ 1550 RPM:	173.7 lb ft (235.4 Nm)
Cooling	Water-cooled

DRIVETRAIN

Travel speeds:	
1st	1.3 mph (2.1 kph)
2nd	2.5 mph (4.1 kph)
Maximum traction force	11,680 lb (5 300 kg)
Gradeability	35° (70%)
Ground pressure	4.8 psi (0.34 kgf/cm ²)

ELECTRICAL

Voltage	12 Volts
Alternator rating	60 amp
Battery	1 x 12 V x 100 Ah 850 CCA

OPERATOR ENVIRONMENT

Enclosed cab w/heat and air conditioning; ISO 6396:2008 sound pressure level LpA=76dB (A); Pilot operated hand controls and foot pedals; Adjustable seat w/seat belt and seat heater; Arm rests; 12V socket; 5.7 in color LCD display; cup holder; Cell phone holder; Bluetooth radio with USB input, 2 speakers and remote control.

Display includes:

Hydraulic oil temp warning lamp; Air cleaner warning lamp; Engine stop warning lamp; Check engine warning lamp; Water in fuel warning lamp; Battery charging warning lamp; Emergency warning lamp; Engine coolant temp warning lamp; Engine oil pressure warning lamp; DPF regeneration inhibit warning lamp; DPF regeneration acknowledge warning lamp; DPF warning lamp; High Exhaust Temperature warning lamp; Low fuel level warning lamp; Engine coolant temperature gauge; Hydraulic oil temperature gauge; Fuel gauge; Engine RPM and Hour meter.

OPERATING WEIGHT

Cab operating weight:	
Short arm	12,270 lb (5 565 kg)
Long arm	12,320 lb (5 590 kg)

NOTE: w/rubber tracks/no quick coupler/bucket/fluids/full of fuel/165 lb operator.

HYDRAULICS

Main pumps:	Variable displacement tandem axial piston pump + gear pump
Max rated flow:	2 x 15.3 + 10.1 gpm (2 x 57.8 + 38.4 L/min)

Auxiliary flow:	
Hammer Circuit 1-way:	
Flow	15.3 gpm (57.8 L/min)
Pressure	3,133 psi (216 bar)
1st Auxiliary 2-way Circuit:	
Flow	15.3 gpm (57.8 L/min)
Pressure	3,133 psi (216 bar)
2nd Auxiliary 2-way Circuit:	
Flow	7.9 gpm (30 L/min)
Pressure	2,321 psi (160 bar)

System relief pressure:	
Standard	3,130 psi (216 bar)
Overload relief valve	3,410 psi (235 bar)

Pilot control hydraulic system:	
Pump	Gear pump
Maximum capacity	2.5 gpm (9.5 L/min)

Control valves:

Pilot control for boom, arm, bucket, and swing
Mechanical control for left/right travel and backfill blade

Swing Motor:	Fixed displacement axial piston motor Automatic spring applied hydraulic released brake
--------------	--

Travel Motor:	Variable displacement axial piston 2-stage planetary Automatic spring applied hydraulic released brake
---------------	--

SERVICE CAPACITIES

Fuel tank	31.7 gal (120 L)
Hydraulic tank:	
Refill capacity	18.5 gal (70 L)
Total system	31.7 gal (120 L)
Engine oil w/filter change	3.1 gal (11.6 L)
Radiator	2.5 gal (9.5 L)

OTHER SPECIFICATIONS

Swing speed	0 – 9.1 RPM
Undercarriage:	
Track rollers	1 upper/5 lower each
Boom:	
Swing	80° left/50° right
Length	9 ft 10 in (3.0 m)
Arm:	
Standard length	5 ft 3 in (1.6 m)
Long arm length	6 ft 3 in (1.9 m)

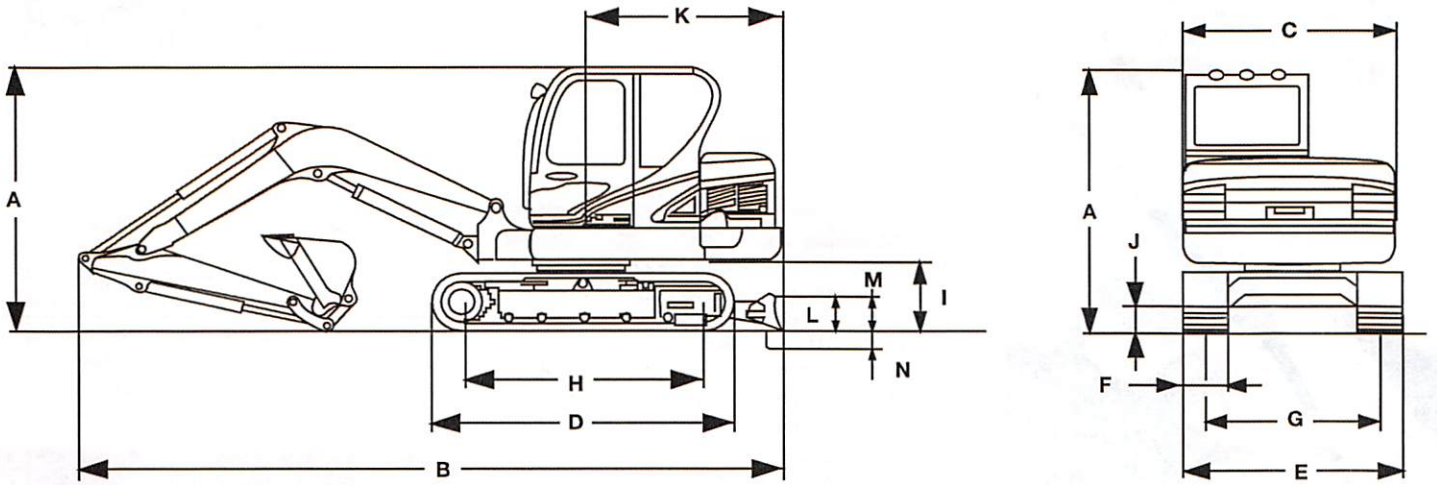

Line drawings are for illustrative purpose only and may not be exact representation of unit.

DIMENSIONS

	5 ft 3 in (1.6 m) Arm
A. Overall height	8 ft 4 in (2 550 mm)
B. Overall transport length	19 ft 4 in (5 900 mm)
C. Width of upper structure	6 ft 1 in (1 850 mm)
D. Track overall length	8 ft 4 in (2 530 mm)
E. Track overall width	6 ft 4 in (1 920 mm)
F. Track shoe width	15 in (380 mm)
G. Track gauge	4 ft 11 in (1 500 mm)
H. Center to center - idler to sprocket	6 ft 6 in (1 990 mm)
I. Upper structure ground clearance	2 ft 3 in (690 mm)
J. Minimum ground clearance	1 ft 3 in (380 mm)
K. Tail swing radius	5 ft 5 in (1 650 mm)
Boom swing	80° left/50° right
Tail swing overhang	2 ft 3 in (690 mm)

BLADE SPECS

L. Backfill blade height	1 ft 2 in (350 mm)
M. Backfill blade rise above ground	1 ft 3 in (390 mm)
N. Backfill blade dig depth	1 ft 11 in (590 mm)
Backfill blade width	6 ft 4 in (1 920 mm)

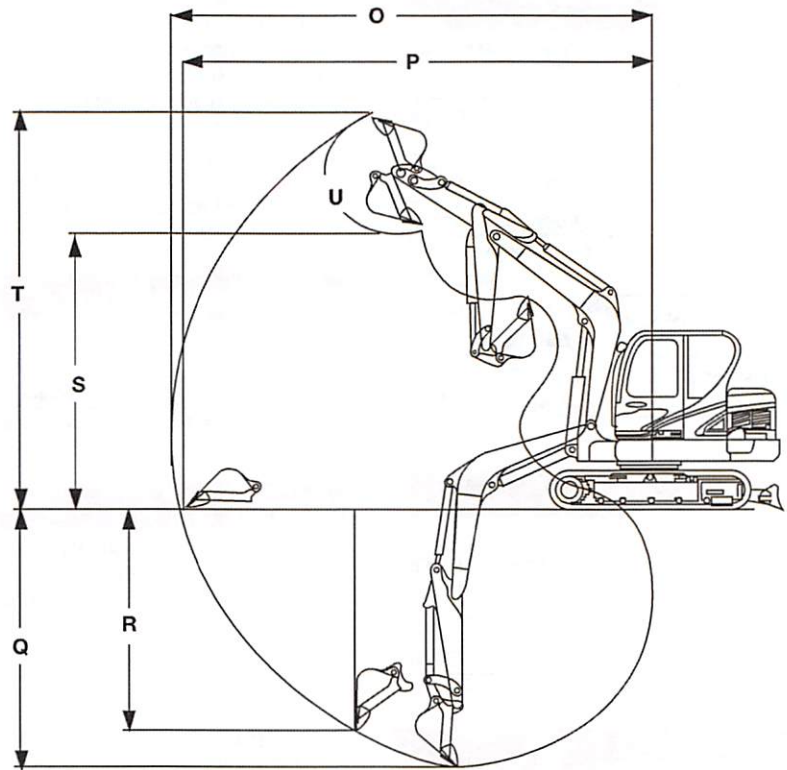

PERFORMANCE SPECS

	5 ft 3 in (1.6 m) Arm	6 ft 3 in (1.9 m) Arm
O. Maximum dig radius	20 ft 2 in (6 150 mm)	21 ft 0 in (6 400 mm)
P. Dig radius at groundline	19 ft 9 in (6 010 mm)	20 ft 7 in (6 270 mm)
Q. Maximum dig depth	12 ft 6 in (3 820 mm)	13 ft 4 in (4 060 mm)
R. Vertical straight wall dig depth	10 ft 6 in (3 200 mm)	11 ft 4 in (3 460 mm)
S. Dump height	13 ft 3 in (4 050 mm)	13 ft 9 in (4 180 mm)
T. Overall reach height	19 ft 0 in (5 780 mm)	19 ft 5 in (5 920 mm)
U. Bucket rotation	180°	180°
Arm digging force - ISO	7,190 lbf (3 260 kgf/31.9 kN)	6,460 lbf (2 930 kgf/28.7 kN)
Bucket digging force - ISO	9,550 lbf (4 330 kgf/42.4 kN)	9,550 lbf (4 330 kgf/42.4 kN)

LIFT CAPACITIES

9 ft 10 in (3.0 m) Boom, 5 ft 3 in (1.6 m) Arm, Dozer Blade Down Cab unit equipped with 0.18 m³ (SAE heaped) bucket, 15 in (380 mm) rubber track and 739 lb (335 kg) counterweight.

Load/Lift Point Height	LOAD RADIUS								MAXIMUM REACH		
	7 ft (2.0 m)		10 ft (3.0 m)		13 ft (4.0 m)		16 ft (5.0 m)		REACH @	CAPACITY	
	END	SIDE	END	SIDE	END	SIDE	END	SIDE		END	SIDE
+13 ft (4.0 m)					2,170 lb* (990 kg)*	2,170 lb* (990 kg)*			14 ft 4 in (4.37 m)	2,220 lb* (1 000 kg)*	1,920 lb (870 kg)
+10 ft (3.0 m)					2,340 lb* (1 060 kg)*	2,220 lb (1 010 kg)			16 ft 3 in (4.96 m)	2,150 lb* (970 kg)*	1,490 lb (670 kg)
+7 ft (2.0 m)	6,610 lb* (3 000 kg)*	6,610 lb* (3 000 kg)*	3,660 lb* (1 660 kg)*	3,400 lb (1 540 kg)	2,850 lb* (1 290 kg)*	2,110 lb (960 kg)	2,530 lb* (1 150 kg)*	1,430 lb (650 kg)	17 ft 3 in (5.26 m)	2,240 lb* (1 010 kg)*	1,290 lb (590 kg)
+3 ft (1.0 m)			5,150 lb* (2 340 kg)*	3,080 lb (1 400 kg)	3,470 lb* (1 580 kg)*	1,970 lb (900 kg)	2,780 lb* (1 260 kg)*	1,370 lb (620 kg)	17 ft 6 in (5.33 m)	2,480 lb* (1 120 kg)*	1,220 lb (550 kg)
Groundline	4,160 lb* (1 890 kg)*	4,160 lb* (1 890 kg)*	5,920 lb* (2 680 kg)*	2,910 lb (1 320 kg)	3,910 lb* (1 770 kg)*	1,870 lb (850 kg)	2,940 lb* (1 330 kg)*	1,320 lb (600 kg)	17 ft 0 in (5.17 m)	2,820 lb* (1 280 kg)*	1,250 lb (570 kg)
-3 ft (-1.0 m)	6,870 lb* (3 120 kg)*	5,770 lb (2 620 kg)	5,890 lb* (2 670 kg)*	2,860 lb (1 300 kg)	3,950 lb* (1 790 kg)*	1,830 lb (830 kg)			15 ft 8 in (4.77 m)	3,040 lb* (1 380 kg)*	1,410 lb (640 kg)
-7 ft (-2.0 m)	8,420 lb* (3 820 kg)*	5,890 lb (2 670 kg)	5,100 lb* (2 310 kg)*	2,910 lb (1 320 kg)	3,330 lb* (1 510 kg)*	1,870 lb (850 kg)			13 ft 2 in (4.01 m)	3,310 lb* (1 500 kg)*	1,860 lb (840 kg)
-10 ft (-3.0 m)	4,700 lb* (2 130 kg)*	4,700 lb* (2 130 kg)*							8 ft 3 in (2.52 m)	3,570 lb* (1 620 kg)*	3,570 lb* (1 620 kg)*

NOTE: Lifting capacity are based on ISO 10567.

Lifting capacity does not exceed 75% of tipping load with the machine on firm, level ground or 87% of full hydraulic capacity.

The lift point is a hook located on the back of the bucket.

*Indicates load limited by hydraulic capacity.

9 ft 10 in (3.0 m) Boom, 6 ft 3 in (1.9 m) Arm, Dozer Blade Down Cab unit equipped with 0.18 m³ (SAE heaped) bucket, 15 in (380 mm) rubber track and 739 lb (335 kg) counterweight.

Load/Lift Point Height	LOAD RADIUS								MAXIMUM REACH		
	7 ft (2.0 m)		10 ft (3.0 m)		13 ft (4.0 m)		16 ft (5.0 m)		REACH @	CAPACITY	
	END	SIDE	END	SIDE	END	SIDE	END	SIDE		END	SIDE
+13 ft (4.0 m)									15 ft 6 in (4.72 m)	1,860 lb* (850 kg)*	1,690 lb (770 kg)
+10 ft (3.0 m)					2,070 lb* (940 kg)*	2,070 lb* (940 kg)*	2,150 lb* (980 kg)*	1,500 lb (680 kg)	17 ft 3 in (5.27 m)	1,800 lb* (820 kg)*	1,350 lb (610 kg)
+7 ft (2.0 m)			3,170 lb* (1 440 kg)*	3,170 lb* (1 440 kg)*	2,610 lb* (1 180 kg)*	2,150 lb (970 kg)	2,360 lb* (1 070 kg)*	1,450 lb (660 kg)	18 ft 3 in (5.55 m)	1,860 lb* (840 kg)*	1,180 lb (540 kg)
+3 ft (1.0 m)			4,770 lb* (2 170 kg)*	3,150 lb (1 430 kg)	3,280 lb* (1 490 kg)*	2,000 lb (910 kg)	2,660 lb* (1 200 kg)*	1,380 lb (630 kg)	18 ft 5 in (5.61 m)	2,030 lb* (920 kg)*	1,120 lb (510 kg)
Groundline	4,070 lb* (1 840 kg)*	4,070 lb* (1 840 kg)*	5,770 lb* (2 620 kg)*	2,930 lb (1 330 kg)	3,800 lb* (1 730 kg)*	1,890 lb (860 kg)	2,890 lb* (1 310 kg)*	1,320 lb (600 kg)	17 ft 11 in (5.46 m)	2,360 lb* (1 070 kg)*	1,140 lb (520 kg)
-3 ft (-1.0 m)	6,160 lb* (2 790 kg)*	5,720 lb (2 600 kg)	5,960 lb* (2 700 kg)*	2,860 lb (1 300 kg)	3,980 lb* (1 800 kg)*	1,830 lb (830 kg)	2,880 lb* (1 310 kg)*	1,300 lb (590 kg)	16 ft 8 in (5.08 m)	2,800 lb* (1 270 kg)*	1,260 lb (570 kg)
-7 ft (-2.0 m)	9,210 lb* (4 180 kg)*	5,820 lb (2 640 kg)	5,400 lb* (2 450 kg)*	2,880 lb (1 300 kg)	3,160 lb* (1 440 kg)*	1,840 lb (830 kg)			14 ft 5 in (4.40 m)	3,050 lb* (1 380 kg)*	1,600 lb (730 kg)
-10 ft (-3.0 m)	6,150 lb* (2 790 kg)*	6,040 lb (2 740 kg)	3,660 lb* (1 660 kg)*	3,010 lb (1 360 kg)					10 ft 4 in (3.16 m)	3,350 lb* (1 520 kg)*	2,770 lb (1 260 kg)

NOTE: Lifting capacity are based on ISO 10567.

Lifting capacity does not exceed 75% of tipping load with the machine on firm, level ground or 87% of full hydraulic capacity.

The lift point is a hook located on the back of the bucket.

*Indicates load limited by hydraulic capacity.

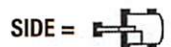
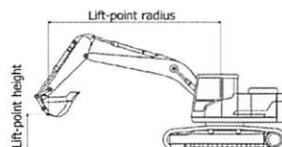

STANDARD EQUIPMENT

ENGINE

Yanmar 4TNV98C
Engine access under rear hood
Glow plug starting aid
Dry type air cleaner with restriction indicator

ELECTRICAL

12-volt electrical starting system
Heavy-duty battery
Battery Master Switch
Key Start
Anti-Theft-Engine starting passwords
Front and rear working lights
12 V power outlet
Auto-idle deature with on/off switch
Horn
Pre-wired – Telematics ready

HYDRAULICS

Auxiliary hydraulics – independent single and bi-directional – and plumbing to arm
Large hydraulic oil cooler
Electronic pattern changer in the cab
Cylinder rod protection covers – Backfill blade and Boom

TRACK DRIVE

Rubber belt tracks
Automatic 2-speed travel
Fully hydrostatic drive system
Sealed and lubricated track rollers
Track tension adjustment – grease type

UPPER STRUCTURE

Conventional radius tail swing
Standard arm: 5 ft 3 in (1.6 m)
Heavy counterweight: 220 lb (100 kg) heavier than standard weight
Bucket linkage with lifting hook
Thumb bracket

OPERATOR ENVIRONMENT

See page 1

OTHER

Swing boom – 80° left/50° right
Hydraulic backfill blade

WARRANTY

Base warranty coverage: 2-Year/3,000-Hour
Full Machine Limited Warranty

OPTIONAL EQUIPMENT

OPERATOR ENVIRONMENT

Rearview camera
Travel alarm

TRACK OPTIONS

Tracks:
Steel Tracks 1 ft 4 in (400 mm)
Steel Tracks 1 ft 6 in (450 mm)
Steel Tracks with bolt on Rubber Pads
1 ft 4 in (400 mm)
Roadliner tracks – steel chain with rubber grousers/shoes 1 ft 4 in (400 mm)
Rubber Belt Tracks 1 ft 4 in (400 mm)
Track guides for steel tracks and steel tracks with bolt on rubber track pads only:
Full
3-piece

OTHER

Optional long arm: 6 ft 3 in (1.9 m)
Hydraulic quick coupler provision
Klacc coupler
Mechanical coupler
Hydraulic hammer
Beacon
2nd auxiliary circuit
Hydraulic coupler

CaseCE.com

©2021 CNH Industrial America LLC. All rights reserved. CASE is a trademark registered in the United States and many other countries, owned by or licensed to CNH Industrial N.V., its subsidiaries or affiliates. CNH Industrial Capital is a trademark in the United States and many other countries, owned by or licensed to CNH Industrial N.V., its subsidiaries or affiliates. Printed in U.S.A. Contains 10% post-consumer fiber.

IMPORTANT: CASE Construction Equipment Inc. reserves the right to change these specifications without notice and without incurring any obligation relating to such change. Availability of some models and equipment builds vary according to the country in which the equipment is used. The illustrations and text may include optional equipment and accessories and may not include all standard equipment. Your CASE dealer/distributor will be able to give you details of the products and their specifications available in your area.



CASE Construction Equipment is biodiesel-friendly. NOTE: All engines meet current EPA emissions regulations. All specifications are stated in accordance with SAE Standards or Recommended Practices, where applicable.



Always read the Operator's Manual before operating any equipment. Inspect equipment before using it, and be sure it is operating properly. Follow the product safety signs and use any safety features provided.

Form No. CCE202108CX57C
Replaces Form No. CCE201806CX57C

CX57C

REQUEST FOR RESOLUTION
FOR COOPERATIVE CONTRACT AWARDS
UNDER 40A:11-12, N.J.A.C. 5:34-7.29 & LFN 2012-10
(REQUIRED FOR PURCHASES OVER \$17,500.00)



4-7-22
(DATE)

1. Goods or Services (detailed description): 1 CASE model TV450B
COMPACT TRACK LOADER FOR MASON CREW / B.A.

2. Amount to be Awarded: \$ 88,831.00

- Encumber Total Award
- Encumber by Supplemental Release

3. Budgeted: By Ordinance No. _____
Or Grant: Title & Year _____

4. **Account Number to be Charged: C-04-00-000-2223-78002

5. Contract Period (if applicable): _____

6. Date to be Awarded: _____

7. Recommended Vendor and Address: GT Mid Atlantic, 551 N. Harding Hwy
Vineland, NJ 08360

8. Justification for Vendor Recommendation: (attach add'l information for Council review)

Type of Contract: State National Regional County

Vendor's Cooperative Contract # Sourcewell 032119 CNH
expires 5/13/23

9. Evaluation Performed by: [Signature]

10. Approved by: [Signature]

11. Attachments:
 Awarding Proposal
 Other: _____

• Send copies to:
Purchasing Department [Signature]
Business Administration

**If more than one account #, provide break down



For Everything Under Construction

SALES ORDER

VINELAND
 551 N. HARDING HWY
 VINELAND, NJ 08360
 856-697-1414

FREEHOLD
 212 MONMOUTH RD.
 FREEHOLD, NJ 07728
 732-780-4600

TOTOWA
 200 BOMONT PLACE
 TOTOWA, NJ 07512
 973-785-4900

**S
O
L
D**

City of Vineland

640 Wood Street

**T
O**

Vineland NJ 08360

TERMS: CASH FINANCE

FINANCE CO: _____ RATE _____ TERM Net 30

SPECIAL FINANCING TERMS: Municipal

REQ. DELIVERY DATE: _____ CUSTOMER PICKUP DEALER DELIVERY

SOLD BY **BOB T**

Date **March 30 2022** Account Number _____ County **Cumberland Co** Contact Person **Don Schultz** Phone _____ Customer P.O. # _____

QTY	NEW/USED/RENTAL	MANUFACTURER	MODEL	SERIAL NUMBER	STOCK NO.	PRICE
1	New	Case	TV450B	TBD	TBD	\$116,664.00
		SOURCEWELL Contract #032119		26% Discount off list		(\$30,333.00)
				Prep, PDI & Delivery		\$2,500.00

<SPECIAL INSTRUCTIONS>
 NEW CASE TV450B
 ALL STANDARD EQUIPMENT INCLUDING THE FOLLOWING
 E-H CAB LCD DISPLAY, HIGH FLOW PLUS PKG, HEAVY DUTY REAR DOOR, AIR RIDE SUSP SEAT, 84" BUCKET W/ BOCE

OPTIONAL ATTACHMENTS: 1) 8'FT Snow Pusher \$3,500.00 2) Hyd Forks \$2,950.00 (not included in price)

TRADE-INS Purchaser hereby bargains, sells and conveys unto Seller the following described Trade-In Equipment and warranties and certifies it to be free and clear of liens, encumbrance, and security interests except to the extent below.					1. SALE PRICE	\$88,831.00
					2. FREIGHT	\$0.00
YEAR	MAKE	MODEL	SERIAL NUMBER	TRADE AMOUNT	3. SUBTOTAL	\$88,831.00
				\$0.00	4. LESS TRADE	\$0.00
					5. RENTS PAID	
OUTSTANDING LOAN WITH		ACCOUNT NUMBER		TOTAL TRADE (LINE 4)	6. ADJUSTED PRICE	\$88,831.00
				OUTSTANDING BAL. OWED (LINE 12)	7. SALES TAX 0.000%	\$0.00
				\$0.00	8. FED EXCISE TAX	
					9. DOC. FEES	\$0.00
					9. TOTAL COST	\$88,831.00
					10. CASH DOWN PAYMENT	
					11. BALANCE DUE (PURCHASE)	\$88,831.00
					12. OUTSTANDING BAL. OF TRADE	\$0.00
					13. TOTAL UNPAID BALANCE	\$88,831.00

CASE PRO CARE: _____

WARRANTIES:

NEW (mfg) _____ **USED-AS IS: No warranty expressed or implied**

OTHER: Terms & Conditions

***ALL WARRANTIES, IF ANY BY A MANUFACTURER OR SUPPLIER OTHER THAN THE DEALER ARE THEIR WARRANTIES, NOT THE DEALERS, AND ONLY SUCH MANUFACTURER OR OTHER SUPPLIER SHALL BE LIABLE FOR PERFORMANCE UNDER SUCH WARRANTIES, UNLESS DEALER FURNISHES BUYER WITH A SEPARATE WRITTEN OR SERVICE CONTRACT MADE BY DEALER ON ITS OWN BEHALF. DEALER HEREBY DISCLAIMS ALL WARRANTIES, EXPRESSED OR IMPLIED, INCLUDING ANY IMPLIED WARRANTIES OF MERCHANTABILITY OR FITNESS FOR PARTICULAR PURPOSE ON ALL GOODS AND SERVICES SOLD BY DEALER AND ON ALL USED PRODUCTS WHICH ARE HEREBY SOLD "AS IS- NOT EXPRESSLY WARRANTIED OR GUARANTEED". ALL WARRANTY REPAIRS MADE UNDER THIS AGREEMENT WILL BE MADE AT THE GROFF TRACTOR NEW JERSEY, LLC SERVICE FACILITY. THE CUSTOMER IS RESPONSIBLE FOR ALL HAULING CHARGES TO AND FROM THE GROFF FACILITY.**

- NOTICE TO BUYER**
1. Read this contract before you sign it.
 2. You are entitled to and exact and completely filled in copy of this contract when you sign it. Keep it to protect your legal rights.
 3. Purchaser acknowledges receipt of a fully completed copy of this contract and Purchaser waives notice of the acceptance or rejection of this order by the seller.
 4. The additional terms and conditions set forth on the reverse side are a part of this contract and are incorporated herein by reference.
 5. Seller retains a security interest in the purchased goods until the price is fully paid.

Accepted for GROFF TRACTOR MID ATLANTIC, LLC

BY: _____ Title _____ Date _____

Purchased by: _____ Company Name _____

X: _____ Purchaser Signature _____ Title _____ Date _____

Groff Tractor Mid Atlantic, LLC
Terms and Conditions

1. PRICES: All Prices quoted herein are exclusive on and City, State or Federal taxes on manufacture, sales, use and the like. Whenever applicable, the buyer shall be solely responsible for payment thereof.

2. PAYMENT: Payments shall become due in accordance with the terms hereof. Finance charges are subject to rate approval by financial institutions. The terms of sale are subject to credit approval and seller may, at any time prior to delivery, modify the terms of payment originally specified to assure prompt payment for the equipment ordered.

3. SECURITY INTEREST: Seller shall retain a security interest in the equipment delivered hereunder until the total selling price, including taxes, delivery and other charges, is paid in full by buyer. Buyer agrees to sign and deliver to seller any additional security agreement required by seller. Buyer hereby appoints seller as buyer's agent to sign and cause to be filed on behalf of buyer any and all financing statements deemed necessary by seller to perfect the security interest granted by buyer to seller hereunder.

4. WARRANTY: Seller warrants each new product within the time period or hourly limitation established by the manufacturer thereof. Seller's sole obligation under this warranty shall be limited to repairing, replacing or allowing credit for, at seller's option, any part or component which under normal and proper use and maintenance proves defective in material or workmanship.

THIS WARRANTY IS IN LIEU OF ALL OTHER WARRANTIES, EXPRESSED OR IMPLIED AND THERE IS NO IMPLIED WARRANTY OF MERCHANTABILITY AND FITNESS FOR A PARTICULAR PURPOSE WHICH EXCEED THE AFORESTATED OBLIGATION ARE HEREBY DISCLAIMED BY SELLER AND EXCLUDED FROM THIS AGREEMENT, UNLESS OTHERWISE EXPRESSLY STATED ON THE FACE OF THIS FORM.

USED PRODUCTS ARE SOLD ON AN "AS IS" BASIS AND THERE IS NO IMPLIED WARRANTY OR MERCHANTABILITY OR OF FITNESS FOR A PARTICULAR PURPOSE, UNLESS OTHERWISE EXPRESSLY STATED ON THE FACE OF THIS FORM.

FURTHER, THERE ARE NO ORAL OR WRITTEN PROMISES, TERMS, CONDITIONS, REPRESENTATIVES OF QUALITY OR FITNESS FOR ANY PURPOSE OR WARRANTIES, EXPRESSED OR IMPLIED, CONCERNING THESE PRODUCTS, OTHER THAN THOSE CONTAINED HEREIN IN WRITING, IF ANY.

BUYER AGREES TO INDEMNIFY AND HOLD TO SELLER HARMLESS FROM AND AGAINST ALL LIABILITY AND EXPENSES BASED UPON DAMAGE TO PROPERTY OR INJURY TO, OR DEATH OF, ANY PERSON ARISING OUT OF OR ATTRIBUTABLE TO THE USE OF SAID MACHINERY.

5. DEFAULT AND REPOSESSION: If buyer shall default in the performance of any of the terms, covenants and conditions of this Agreement, seller may declare the full amount due and payable without notice or demand and may repossess the equipment. Buyer agrees to pay attorney's fees in the amount of twenty percent (20%) of the amount due and payable, together with any other expenses incurred. Buyer shall be responsible for any expenses incurred by seller or its agents repossessing any item of equipment.

6. DELAYS: Seller may not be liable for loss or damage due to delay in delivery, resulting from any cause beyond seller's reasonable control including, but not limited to, acts of God, acts of omissions of the buyer, acts of civil or military authority, fires, strikes, factory shutdowns or alterations, embargos, war, riot or delay in transportation.

7. INSURANCE: The buyer shall at his own expense, but in the name for and in the benefit of the seller, insure said equipment against loss that may occur or be caused by fire, flood, explosion, theft or otherwise and liability of any and every kind until the selling price is paid in full by the buyer.

8. CANCELLATION: Buyer may cancel its order, reduce quantities, revise specifications or extend schedules only by mutual agreement as to reasonable and proper cancellation charges which shall take into account expenses already incurred and commitments made by the seller against any loss resulting there from.

INITIALS



ENGINE

Model	FPT F5B FL413 D*C001
Emissions Certification	Tier 4 Final
Type	Diesel 4-stroke, Turbo, D.I.
Cylinders	4
Bore/Stroke	3.9 x 4.3 in (99 x 110 mm)
Displacement	207 in ³ (3.4 L)
Fuel injection	Direct, high pressure common rail – HPCR
Fuel	#2 Diesel
Fuel filter:	
Pre-filter	Beta (30) = 200/spin-on
Main filter	Beta (4) = 20/spin-on
Air intake	Turbocharged w/ waste gate and external cooled EGR
Exhaust aftertreatment	Selective Catalytic Reduction (SCR)
Cooling	Liquid
Engine speeds	RPM
High idle – no load	2500 +/- 25
Rated – full load	2500
Low idle	1150 +/- 25
Horsepower @ 2500 RPM – SAE J1349:	
Gross	90 hp (67 kW)
Net	84 hp (63 kW)
Peak torque @ 1400 RPM	282 lb-ft (383 N-m)
Radiator:	
Core type	Aluminum bar and plate
Core size area	319 in ² (0.206 m ²)
Rows of tubes x columns	21 rows
Cap pressure	16 +/- 2 psi (1.10 +/- 0.14 bar)
Fan:	
Diameter	22 in (560 mm)
Ratio	0.96:1 standard, 1.1:1 high-flow
Water pump:	
Style	Centrifugal
Flow	47.8 gpm (181 L/min)
Engine lubrication pump:	
Rotor pump w/ deep sump pan, plate cooler and pressurized under-piston nozzles	
Pump operating angle ratings:	
Side to side	45°
Bucket up	35°
Bucket Down	45°

LIFT GEOMETRY

Vertical Lift

DRIVETRAIN

Drive pump controls	Servo-assist mechanical
Pump to engine ratio	1:1
Displacement	2.81 in ³ (46 cm ³)
Flow @ rated engine RPM:	
@ 97% efficiency	29.4 gpm (111 L/min)
Charge pressure	360 psi (24.5 bar)
System relief pressure	5,220 psi (360 bar)

Drive pump controls	Electro-hydraulic
Pump to engine ratio	1:1
Displacement	2.75 in ³ (45 cm ³)
Flow @ rated engine RPM:	
@ 97% efficiency	28.8 gpm (109 L/min)
Charge pressure	362 psi (24.5 bar)
System relief pressure	5,220 psi (360 bar)

Drive motors:	
Max. displacement	3.10 in ³ (50.9 cm ³)
Displacement:	
High speed	2.02 in ³ (33.1 cm ³)
Motor RPM @ high idle and 97% efficiency:	
2-speed	156
Motor torque @ max. displacement and relief pressure, calculated @ 5,220 psi (360 bar):	4,654 lb-ft (6 310 N-m)

Travel speed:	
Low range	5.5 mph (8.9 kph)
High range	8.0 mph (12.9 kph)

Final drive:	
Planetary gearbox w/ 2-speed motor	

Tractive effort	7,414 lb (3 370 kg)
-----------------	---------------------

Parking brake:	
Type	Spring-applied, hydraulic release multiple disc.
Engagement	Depress on/off brake button on handle or instrument panel, raise seat bar, get off seat or stop engine.

ELECTRICAL

Alternator	160 amp
Starter	4.29 hp (3.2 kW)
Battery	12-volt low-maintenance 1,000 cold-cranking amps @ 0° F (-18° C°)

OPERATOR ENVIRONMENT

ROPS/FOPS Level 1 canopy w/ side screens; Keyed start ignition; Tilt ROPS/FOPS; Rear window w/ emergency escape; Suspension Seat, vinyl w/ 2 in (51 mm) retractable 3 point lap seat belt; Hand and foot throttles; Alarm package – back-up and horn; Rearview mirror; Headliner; Dome Light; Top window; Cup holder; 12V Power plug socket; Foot rest; Seat pocket; Padded seat bar w/ integral armrests; Loader control lockout system; Electric parking brake control; Operator's compartment floor cleanout; Proportional

auxiliary hydraulic control – on joystick; Advanced Instrument Cluster w/ digital hour meter, tachometer, Fuel level LCD bar graph w/ alarm, diagnostic features and security lockout; Electro-hydraulic controls: For drive/steering, loader functions, Switchable between H and ISO patterns, Adjustable sensitivity of controls.

Warning lights with alarms:
Engine coolant temperature; Engine oil pressure; Engine malfunction; Hydraulic charge pressure; Hydraulic filter restriction; Hydraulic oil temperature: Critical system stop, Engine system, Hydraulic system, Electrical and diagnostic system.

Warning alarms:
Battery voltage – plus display; Oil service.

Indicator light:
Engine preheat; Parking brake;
Seat bar reminder.

OPERATING WEIGHT

Unit equipped w/ open cab; 165 lb operator;
78 in Heavy Duty bucket; full of fuel:
10,610 lb (4 823 kg)

Shipping weight 10,267 lb (4 667 kg)

Add-on weights:	
Side cab glass	47 lb (21.3 kg)
Polycarbonate cab door	75 lb (34.0 kg)
Glass cab door w/ wiper	75 lb (34.0 kg)
Suspension seat	22 lb (10.0 kg)
Additional counterweight	600 lb (273 kg)

HYDRAULICS

Implement pump type	Gear
---------------------	------

Displacement:	
Standard aux.	2.23 in ³ (36.6 cm ³)
High-flow aux.	1.42 in ³ (23.3 cm ³)

Standard flow @ rated engine RPM:
@ 100% efficiency 24.2 gpm (91.5 L/min)

Optional high-flow @ rated engine RPM:
@ 100% efficiency 39.5 gpm (149 L/min)

Enhanced high-flow @ rated engine RPM:
@ 100% efficiency 35.0 gpm (132.5 L/min)

Loader control valve:	
Type	3 spool/open center/series - series
Relief pressure	3,450 psi (238 bar)

Port relief pressures:	
Loader raise	3,625 psi (250 bar)
Bucket curl	3,916 psi (270 bar)
Bucket dump	3,625 psi (250 bar)

Hydraulic lines:	
Tubing	ORFS + 37° JIC Flare
Loop hoses	SAE 100 R19

Hydraulic oil cooler:	
Number of fins	10 per inch (3.94 per cm)
Number of tube rows x columns	9 bar/plate
Area	138.7 in ² (890 cm ²)

Hydraulic filter	Beta (4) = 75/spin-on
------------------	-----------------------

HYDRAULICS CONT.

Lift cylinders:	
Bore diameter	2.75 in (69.85 mm)
Rod diameter	1.75 in (44.5 mm)
Stroke	35.7 in (908 mm)
Closed length	53.9 in (1 369 mm)

Bucket cylinders:	
Bore diameter	3.0 in (76.2 mm)
Rod diameter	1.5 in (38.1 mm)
Stroke	15.9 in (405 mm)
Closed length	24.3 in (617.0 mm)

SERVICE CAPACITIES

Fuel Tank	25.5 gal (96.5 L)
Engine oil w/ filter	8.9 qt (8.5 L)
Hydraulic system:	
Reservoir	6.0 gal (22.7 L)
Total	11.9 gal (45.4 L)
Diesel Exhaust Fluid (DEF) Tank	2.8 gal (10.7 L)

PERFORMANCE SPECS

Rated operating capacity – ROC*:	
35% of tipping load	3,150 lb (1 432 kg)
50% of tipping load	4,500 lb (2 045 kg)
w/ additional counterweight	4,700 lb (2 135 kg)

Tipping load*	9,000 lb (4 091 kg)
---------------	---------------------

Breakout forces @ 3,150 psi (217 bar)*:	
Bucket Cylinders	9,188 lb (41.8 kN)
Lift cylinders – hydraulic limit	7,773 lb (35.3 kN)

Cycle times:	
Raise	5.1 sec
Lower	3.5 sec
Dump	2.7 sec
Roll back	2.0 sec

NOTE: *Measured using 78 in (1.98 m) heavy-duty bucket.

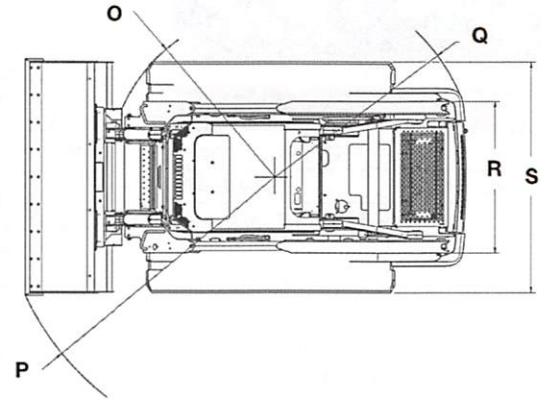
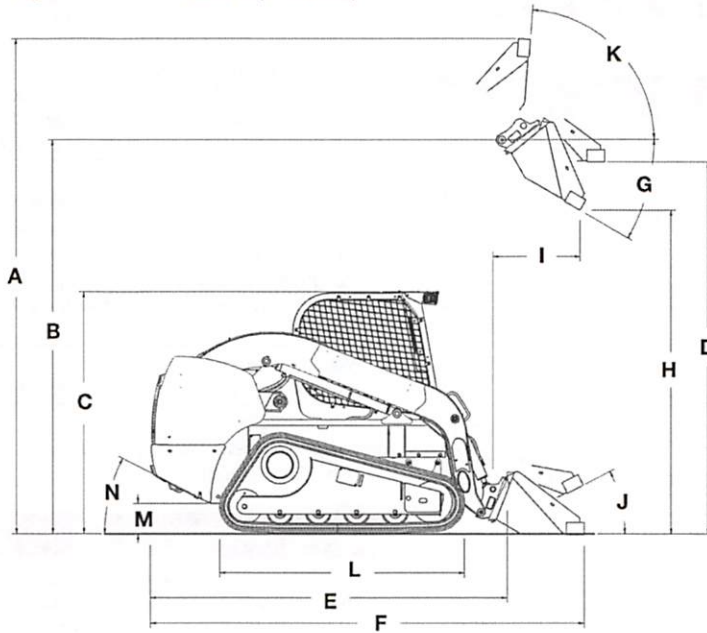

Line drawings are for illustrative purpose only and may not be exact representation of unit.

DIMENSIONS

A. Overall operating height:	
with foundry/excavating bucket	161.4 in (4.10 m)
with heavy duty bucket	165.6 in (4.21 m)
with low profile extended bucket	170.4 in (4.33 m)
Height to:	
B. Bucket hinge pin	131.6 in (3.34 m)
C. Top of ROPS	80.4 in (2.04 m)
D. Bottom of level bucket, fully raised	123.2 in (3.13 m)
Overall length:	
E. without attachment with coupler	120.2 in (3.05 m)
F. with foundry/excavating bucket on ground	144.4 in (3.67 m)
with heavy duty bucket	148.6 in (3.78 m)
with low profile extended bucket	153.5 in (3.89 m)
G. Maximum dump angle	45.3°
H. Dump height:	
with foundry/excavating bucket	104.1 in (2.65 m) @ 45.0°
with heavy duty bucket	101.1 in (2.57 m) @ 45.0°
I. Dump reach at maximum height with low profile extended bucket	35.1 in (0.89 m) @ 45.0°
Maximum attachment rollback:	
J. Bucket on ground	32.0°
K. Bucket at full height	83.1°
L. Track on ground	64.5 in (1.64 m)
M. Ground clearance – bottom of belly pan	9.5 in (0.24 m)
N. Angle of departure	32.0°
Clearance circle:	
O. without bucket	57.7 in (1.47 m)
P. with 78 in (1.98 m) foundry/excavating bucket on ground	87.8 in (2.23 m)
Q. Clearance circle rear	68.6 in (1.74 m)
R. Track gauge	58.6 in (1.49 m)
S. Over the track width	76.5 in (1.94 m)

TRACK SELECTION

Type	Area	Ground Pressure	Width to Outside Track
17.7 in (450 mm)	2,286 in ² (1.48 m ²)	4.6 psi (31.7 kPa)	76 in (1.93 m)

OPTIONAL BUCKETS

Type	Width	Weight	Heaped Capacity
Dirt & Foundry	78 in (1.98 m)	440 lb (200 kg)	17.7 ft ³ (0.50 m ³)
Low Profile Extended	78 in (1.98 m)	540 lb (245 kg)	19.1 ft ³ (0.54 m ³)
	84 in (2.13 m)	575 lb (262 kg)	20.5 ft ³ (0.58 m ³)
Light Material	84 in (2.13 m)	540 lb (245 kg)	27.5 ft ³ (0.78 m ³)
Heavy-Duty	78 in (1.98 m)	530 lb (240 kg)	15.5 ft ³ (0.44 m ³)
	84 in (2.13 m)	550 lb (250 kg)	17.0 ft ³ (0.48 m ³)
Heavy-Duty Extended with SmartFit Teeth	78 in (1.98 m)	697 lb (316 kg)	18.9 ft ³ (0.54 m ³)
	84 in (2.13 m)	728 lb (330 kg)	20.5 ft ³ (0.58 m ³)

STANDARD EQUIPMENT

OPERATOR ENVIRONMENT

See page 1

ENGINE

Dual element air cleaner
Organic Acid Technology (OAT)
Anti-freeze solution to -34° F
Fuel tank - 25.5 gal (U.S.)
Over and under radiator and oil cooler
3-stack after cooler/radiator/oil cooler configuration
Glow plugs
Integral engine oil cooler
Fuel filter with water trap
1,000 CCA 12V battery
Master electrical disconnect
Jump start terminal

OPTIONAL EQUIPMENT

OPERATOR ENVIRONMENT

Enclosed cab:
Fully sealed and pressurized – FSP
Glass door with wiper and washer
Sliding side windows – removable
Ventilation system with integrated heater
Heater and air conditioner
AM/FM Bluetooth radio with 2 speakers and USB port
Keyless start ignition
8 in Color LCD Display
Economy Mode (auto idle shutdown)
Auto Engine Protection Shutdown
Mechanical hand controls
Hand and foot controls:
Hand controls the loader drive function and foot controls the bucket and boom
Deluxe cloth, air suspension seat, with heater and lumbar support
Demolition cab door with polycarbonate
Ignition Timeout
Machine Settings User Access Levels
Operator Security Codes

DRIVETRAIN

2-speed hydrostatic four wheel drive
SAHR disc parking brake

HYDRAULICS

Auxiliary hydraulics:
@ 3,450 psi (238 bar) – 24.2 gpm (91.5 L/min)
6 micron oil filtration system
3-spool loader control valve
Auxiliary hydraulic disconnects, ISO flat-face – connect-under-pressure with case drain
Hydraulic circuit pedal lock
Auxiliary function lockout override
Loader lift lockout override
Heavy-duty hydraulic oil cooler
Loader arm float position
Loader function lockout system

HYDRAULICS

High-flow auxiliary hydraulics – combined:
@ 3,450 psi (238 bar) – 39.5 gpm (149 L/min)
Enhanced High-Flow auxiliary hydraulics – EHF:
@ 4,000 psi (276 bar) – 35.0 gpm (132.5 L/min)
Second auxiliary hydraulics
Hydraulic one-way self-leveling
Ride control

LOADER

Auxiliary front electric control
Hydraulic attachment coupler

DRIVETRAIN

Creep Speed Mode

OTHER

Language decals
Buckets – see page 3

LOADER

Manual attachment coupler
Vertical lift geometry
Loader lift arm support strut
SAE operating load: 3,150 lbs
Tipping load: 9,000 lbs

TRACKS

Rubber Tracks

OTHER STANDARD FEATURES

Halogen lights - 2 front, 2 side, 2 rear flood
Pre-wired for rotating beacon
Lockable service access hood
Single-point daily servicing
Rear tail lights
Remote oil and fuel filters
Block heater
Debris ingress sealing
Mounting points for add-on counterweights

Bolt-on bucket cutting edges
Bolt-on heavy-duty bucket spill guard
Special paint
Offsite service arrangement
SiteWatch Telematics

FACTORY SUPPLIED ATTACHMENTS

Rotating beacon
Four point lift hook
48 in (1.22 m) pallet forks

SERVICE PARTS

Add-on counterweights
Road lights
Four-corner LED strobe
Single point lift hook
Aspirator
Precleaner
FOPS Level 2
3 inch (76.2 mm) retractable seat belt
Bolt-on heavy-duty bucket teeth

CaseCE.com

©2020 CNH Industrial America LLC. All rights reserved. CASE is a trademark registered in the United States and many other countries, owned by or licensed to CNH Industrial N.V., its subsidiaries or affiliates. CNH Industrial Capital is a trademark in the United States and many other countries, owned by or licensed to CNH Industrial N.V., its subsidiaries or affiliates. Printed in U.S.A. Contains 10% post-consumer fiber.

IMPORTANT: CASE Construction Equipment Inc. reserves the right to change these specifications without notice and without incurring any obligation relating to such change. Availability of some models and equipment builds vary according to the country in which the equipment is used. The illustrations and text may include optional equipment and accessories and may not include all standard equipment. Your CASE dealer/distributor will be able to give you details of the products and their specifications available in your area.



CASE Construction Equipment is biodiesel-friendly. NOTE: All engines meet current EPA emissions regulations. All specifications are stated in accordance with SAE Standards or Recommended Practices, where applicable.



Always read the Operator's Manual before operating any equipment. Inspect equipment before using it, and be sure it is operating properly. Follow the product safety signs and use any safety features provided.

Form No. CCE202009TV450B
Replaces Form No. CCE202001TV450B

TV450B

REQUEST FOR RESOLUTION
FOR COOPERATIVE CONTRACT AWARDS
UNDER 40A:11-12, N.J.A.C. 5:34-7.29 & LFN 2012-10
(REQUIRED FOR PURCHASES OVER \$17,500.00)



5-8-22
(DATE)

1. Goods or Services (detailed description): 2 CASE WHEEL Loaders model 821G
FOR Public Works

2. Amount to be Awarded: \$ 620,918.00

- Encumber Total Award
- Encumber by Supplemental Release

3. Budgeted: By Ordinance No. _____
Or Grant: Title & Year _____

4. **Account Number to be Charged: C-04-00-000-2223-78002

5. Contract Period (if applicable): _____

6. Date to be Awarded: _____

7. Recommended Vendor and Address: GT mid ATLANTIC
551 N HARDING HWY
VINELAND N.J. 08360

8. Justification for Vendor Recommendation:(attach add'l information for Council review)

Type of Contract: State National Regional County

Vendor's Cooperative Contract # Sourcewell 98204 032119 CNH

9. Evaluation Performed by: Don Lohm

10. Approved by: [Signature]

11. Attachments:
 Awarding Proposal
 Other: _____

• Send copies to:
Purchasing Department
Business Administration [Signature]

**If more than one account #, provide break down



Mid Atlantic

For Everything Under Construction

VINELAND
551 N. HARDING HWY
VINELAND, NJ 08360
856-697-1414

SALES ORDER

FREEHOLD
212 MONMOUTH RD.
FREEHOLD, NJ 07728
732-780-4600

TOTOWA
200 BOMONT PLACE
TOTOWA, NJ 07512
973-785-4900

SOLD TO

City of Vineland
640 Wood Street
Vineland, NJ 08360

TERMS: [X] CASH [] FINANCE
FINANCE CO: RATE TERM Net 30
SPECIAL FINANCING TERMS: Municipal
REQ. DELIVERY DATE: [] CUSTOMER PICKUP [X] DEALER DELIVERY
SOLD BY Bob T

Date April 6 2022
Account Number Sourcewell # 98204
County Cumberland
Contact Person Don Schultz/Jim Neher
Phone
Customer P.O. #

Table with columns: QTY, NEW/USED/RENTAL, MANUFACTURER, MODEL, SERIAL NUMBER, STOCK NO., PRICE. Includes rows for Case 821G, Sourcewell Contract #032119 CNH, DEALER INSTALLED, PREP PDI, & DELIVERY, and EXTENDED WARRANTY.

<SPECIAL INSTRUCTIONS>

TWO (2) NEW CASE 821G WHEEL LOADERS
RIDE CONTROL, 23.5R25 L3 TIRES W 3PC RIM, LIMITED SLIP DIFFS, 4 CYD BUCKET W/ JRB STYLE COUPLER,
COLD WEATHER PACKAGE, ENHANCED COMFORT PACKAGE, ENHANCED VISIBILITY PACKAGE, SKID PLATE GUARDS
JRB FORKS EXTENDED WARRANTY 5YR/7500 HRS
CASE PROCARE <- CASE PREMIER WARRANTY <- CASE SITEWATCH TELEMATICS

TRADE-INS Purchaser hereby bargains, sells and conveys unto Seller the following described Trade-In Equipment and warranties and certifies it to be free and clear of liens, encumbrance, and security interests except to the extent below.
Table with columns: YEAR, MAKE, MODEL, SERIAL NUMBER, TRADE AMOUNT. Includes rows for SUBTOTAL, LESS TRADE, ADJUSTED PRICE, SALES TAX, FED EXCISE TAX, DOC. FEES, TOTAL COST.

[X] CASE PRO CARE: CASE PROCARE/ SITEWATCH/ PREMIER WARRANTY

WARRANTIES:

[X] NEW (mfg)
[] USED-AS IS: No warranty expressed or implied
[] OTHER: Terms & Conditions

*ALL WARRANTIES, IF ANY BY A MANUFACTURER OR SUPPLIER OTHER THAN THE DEALER ARE THEIR WARRANTIES, NOT THE DEALERS, AND ONLY SUCH MANUFACTURER OR OTHER SUPPLIER SHALL BE LIABLE FOR PERFORMANCE UNDER SUCH WARRANTIES, UNLESS DEALER FURNISHES BUYER WITH A SEPARATE WRITTEN OR SERVICE CONTRACT MADE BY DEALER ON ITS OWN BEHALF. DEALER HEREBY DISCLAIMS ALL WARRANTIES, EXPRESSED OR IMPLIED, INCLUDING ANY IMPLIED WARRANTIES OF MERCHANTABILITY OR FITNESS FOR PARTICULAR PURPOSE ON ALL GOODS AND SERVICES SOLD BY DEALER AND ON ALL USED PRODUCTS WHICH ARE HEREBY SOLD "AS IS- NOT EXPRESSLY WARRANTED OR GUARANTEED". ALL WARRANTY REPAIRS MADE UNDER THIS AGREEMENT WILL BE MADE AT THE GROFF TRACTOR NEW JERSEY, LLC SERVICE FACILITY. THE CUSTOMER IS RESPONSIBLE FOR ALL HAULING CHARGES TO AND FROM THE GROFF FACILITY.

Table with columns: Description, Amount. Includes rows: 1. SALE PRICE \$620,918.00, 2. FREIGHT \$0.00, 3. SUBTOTAL \$620,918.00, 4. LESS TRADE \$0.00, 5. RENTS PAID, 6. ADJUSTED PRICE \$620,918.00, 7. SALES TAX 0.000% \$0.00, 8. FED EXCISE TAX, 9. DOC. FEES \$0.00, 9. TOTAL COST \$620,918.00, 10. CASH DOWN PAYMENT, 11. BALANCE DUE (PURCHASE) \$620,918.00, 12. OUTSTANDING BAL. OF TRADE \$0.00, 13. TOTAL UNPAID BALANCE \$620,918.00

- 1. Read this contract before you sign it.
2. You are entitled to and exact and completely filled in copy of this contract when you sign it. Keep it to protect your legal rights.
3. Purchaser acknowledges receipt of a fully completed copy of this contract and Purchaser waives notice of the acceptance or rejection of this order by the seller.
4. The additional terms and conditions set forth on the reverse side are a part of this contract and are incorporated herein by reference.
5. Seller retains a security interest in the purchased goods until the price is fully paid.

Accepted for GROFF TRACTOR MID ATLANTIC, LLC

Purchased by: _____
Company Name

BY: _____
Groff Tractor NJ Signature Title Date

X: _____
Purchaser Signature Title Date

**Groff Tractor Mid Atlantic, LLC
Terms and Conditions**

1. PRICES: All Prices quoted herein are exclusive on and City, State or Federal taxes on manufacture, sales, use and the like. Whenever applicable, the buyer shall be solely responsible for payment thereof.

2. PAYMENT: Payments shall become due in accordance with the terms hereof. Finance charges are subject to rate approval by financial institutions. The terms of sale are subject to credit approval and seller may, at any time prior to delivery, modify the terms of payment originally specified to assure prompt payment for the equipment ordered.

3. SECURITY INTEREST: Seller shall retain a security interest in the equipment delivered hereunder until the total selling price, including taxes, delivery and other charges, is paid in full by buyer. Buyer agrees to sign and deliver to seller any additional security agreement required by seller. Buyer hereby appoints seller as buyer's agent to sign and cause to be filed on behalf of buyer any and all financing statements deemed necessary by seller to perfect the security interest granted by buyer to seller hereunder.

4. WARRANTY: Seller warrants each new product within the time period or hourly limitation established by the manufacturer thereof. Seller's sole obligation under this warranty shall be limited to repairing, replacing or allowing credit for, at seller's option, any part or component which under normal and proper use and maintenance proves defective in material or workmanship.

THIS WARRANTY IS IN LIEU OF ALL OTHER WARRANTIES, EXPRESSED OR IMPLIED AND THERE IS NO IMPLIED WARRANTY OF MERCHANTABILITY AND FITNESS FOR A PARTICULAR PURPOSE WHICH EXCEED THE AFORESTATED OBLIGATION ARE HEREBY DISCLAIMED BY SELLER AND EXCLUDED FROM THIS AGREEMENT, UNLESS OTHERWISE EXPRESSLY STATED ON THE FACE OF THIS FORM. USED PRODUCTS ARE SOLD ON AN "AS IS" BASIS AND THERE IS NO IMPLIED WARRANTY OR MERCHANTABILITY OR OF FITNESS FOR A PARTICULAR PURPOSE, UNLESS OTHERWISE EXPRESSLY STATED ON THE FACE OF THIS FORM.

FURTHER, THERE ARE NO ORAL OR WRITTEN PROMISES, TERMS, CONDITIONS, REPRESENTATIVES OF QUALITY OR FITNESS FOR ANY PURPOSE OR WARRANTIES, EXPRESSED OR IMPLIED, CONCERNING THESE PRODUCTS, OTHER THAN THOSE CONTAINED HEREIN IN WRITING, IF ANY.

BUYER AGREES TO INDEMNIFY AND HOLD TO SELLER HARMLESS FROM AND AGAINST ALL LIABILITY AND EXPENSES BASED UPON DAMAGE TO PROPERTY OR INJURY TO, OR DEATH OF, ANY PERSON ARISING OUT OF OR ATTRIBUTABLE TO THE USE OF SAID MACHINERY.

5. DEFAULT AND REPOSESSION: If buyer shall default in the performance of any of the terms, covenants and conditions of this Agreement, seller may declare the full amount due and payable without notice or demand and may repossess the equipment. Buyer agrees to pay attorney's fees in the amount of twenty percent (20%) of the amount due and payable, together with any other expenses incurred. Buyer shall be responsible for any expenses incurred by seller or its agents repossessing any item of equipment.

6. DELAYS: Seller may not be liable for loss or damage due to delay in delivery, resulting from any cause beyond seller's reasonable control including, but not limited to, acts of God, acts of omissions of the buyer, acts of civil or military authority, fires, strikes, factory shutdowns or alterations, embargos, war, riot or delay in transportation.

7. INSURANCE: The buyer shall at his own expense, but in the name for and in the benefit of the seller, insure said equipment against loss that may occur or be caused by fire, flood, explosion, theft or otherwise and liability of any and every kind until the selling price is paid in full by the buyer.

8. CANCELLATION: Buyer may cancel its order, reduce quantities, revise specifications or extend schedules only by mutual agreement as to reasonable and proper cancellation charges which shall take into account expenses already incurred and commitments made by the seller against any loss resulting there from.

INITIALS

REQUEST FOR RESOLUTION
FOR COOPERATIVE CONTRACT AWARDS
UNDER 40A:11-12, N.J.A.C. 5:34-7.29 & LFN 2012-10
(REQUIRED FOR PURCHASES OVER \$17,500.00)



5-8-22
(DATE)

1. Goods or Services (detailed description): ① CASE 580SWT BACKHOE FOR PUBLIC WORKS
 2. Amount to be Awarded: \$ 130,511.00
 Encumber Total Award
 Encumber by Supplemental Release
 3. Budgeted: By Ordinance No. _____
Or Grant: Title & Year _____
 4. **Account Number to be Charged: C-04-00-000-2223-78002
 5. Contract Period (if applicable): _____
 6. Date to be Awarded: _____ *Per Mr. Mercado*
 7. Recommended Vendor and Address: GROFF TRACTOR GT Mid Atlantic
551 N HARDENS HWY
VINELAND N.J. 08360
 8. Justification for Vendor Recommendation: (attach add'l information for Council review)

- Type of Contract: State National Regional County
- Vendor's Cooperative Contract # Sourcewell 98204 - 032119 CN#
9. Evaluation Performed by: Don John
 10. Approved by: [Signature]
 11. Attachments:
 Awarding Proposal
 Other: _____

• Send copies to:
Purchasing Department
Business Administration *(initials)*
**If more than one account #, provide break down

SALES ORDER



VINELAND
551 N. HARDING HWY
VINELAND, NJ 08360
856-697-1414

FREEHOLD
212 MONMOUTH RD.
FREEHOLD, NJ 07728
732-780-4600

TOTOWA
200 BOMONT PLACE
TOTOWA, NJ 07512
973-785-4900

For Everything Under Construction

S
O
L
D

T
O

City of Vineland
640 Wood Street
Vineland NJ 08360

TERMS: <input checked="" type="checkbox"/> CASH <input type="checkbox"/> FINANCE		
FINANCE CO:	RATE	TERM
		Net 30
SPECIAL FINANCING TERMS: Municipal		
REQ. DELIVERY DATE:	<input type="checkbox"/> CUSTOMER PICKUP	SOLD BY
	<input checked="" type="checkbox"/> DEALER DELIVERY	BOB T

Date April 7 2022	Account Number Sourcewell #98204	County Cumberland Co	Contact Person Don Schultz/ Jim Neher	Phone	Customer P.O. #
----------------------	--	-------------------------	--	-------	-----------------

QTY	NEW USED RENTAL	MANUFACTURER	MODEL	SERIAL NUMBER	STOCK NO.	PRICE
1	New	Case	580SNWT	TBD	TBD	\$189,787.00
		SOURCEWELL Contract #032119		37% Discount off list		(\$70,221.00)
		Dealer Installed		93" GP Bucket		\$3,100.00
				3YR/3000HR Extended Warranty		\$2,345.00
				Prep, PDI & Delivery		\$5,500.00
				TOTAL		\$130,511.00
		OPTIONAL ATTACHMENT		48" Forks		\$6,550.00
		OPTIONAL ATTACHMENT		120" Snow Pusher		\$4,400.00

<SPECIAL INSTRUCTIONS>
NEW CASE 580SNWT BACKHOE LOADER
POWER H TYPE TRANS, 1 WAY/ 2WAY HYD, EHOE, FLIP OVER STAB PADS, 24" BUCKET, MECH QC, HYD THUMB,
COMFORT STEER, RIDE CONTROL, 3RD SPOOL VALVE, HYD COUPLER, 93" GP BUCKET, CAB 2 DOORS, PREM AIR SUSP SEAT,
LED LIGHT PACKAGE, 3YR SITWATCH TELEMATICS SUBSCRIPTION, EXTENDED 3YR OR 3000HR PREMIER WARRANTY
ATTACHMENTS PRICE NOT INCLUDED IN TOTAL: OPTION 1) 48" FORKS \$6,550 OPTION 2) 120" SNOW PUSHER \$4,400

TRADE-INS Purchaser hereby bargains, sells and conveys unto Seller the following described Trade-In Equipment and warranties and certifies it to be free and clear of liens, encumbrance, and security interests except to the extent below.					1. SALE PRICE	\$130,511.00
					2. FREIGHT	\$0.00
					3. SUBTOTAL	\$130,511.00
					4. LESS TRADE	\$0.00
					5. RENTS PAID	
					6. ADJUSTED PRICE	\$130,511.00
					7. SALES TAX 0.000%	\$0.00
					8. FED EXCISE TAX	
					9. DOC. FEES	\$0.00
					9. TOTAL COST	\$130,511.00
					10. CASH DOWN PAYMENT	
					11. BALANCE DUE (PURCHASE)	\$130,511.00
					12. OUTSTANDING BAL. OF TRADE	\$0.00
					13. TOTAL UNPAID BALANCE	\$130,511.00

CASE PRO CARE: _____

WARRANTIES:

NEW (mfg) _____ USED-AS IS: No warranty expressed or implied

OTHER: Terms & Conditions

*ALL WARRANTIES, IF ANY BY A MANUFACTURER OR SUPPLIER OTHER THAN THE DEALER ARE THEIR WARRANTIES, NOT THE DEALERS, AND ONLY SUCH MANUFACTURER OR OTHER SUPPLIER SHALL BE LIABLE FOR PERFORMANCE UNDER SUCH WARRANTIES, UNLESS DEALER FURNISHES BUYER WITH A SEPARATE WRITTEN OR SERVICE CONTRACT MADE BY DEALER ON ITS OWN BEHALF. DEALER HEREBY DISCLAIMS ALL WARRANTIES, EXPRESSED OR IMPLIED, INCLUDING ANY IMPLIED WARRANTIES OF MERCHANTABILITY OR FITNESS FOR PARTICULAR PURPOSE ON ALL GOODS AND SERVICES SOLD BY DEALER AND ON ALL USED PRODUCTS WHICH ARE HEREBY SOLD "AS IS- NOT EXPRESSLY WARRANTED OR GUARANTEED". ALL WARRANTY REPAIRS MADE UNDER THIS AGREEMENT WILL BE MADE AT THE GROFF TRACTOR NEW JERSEY, LLC SERVICE FACILITY. THE CUSTOMER IS RESPONSIBLE FOR ALL HAULING CHARGES TO AND FROM THE GROFF FACILITY.

1. Read this contract before you sign it.
2. You are entitled to an exact and completely filled in copy of this contract when you sign it. Keep it to protect your legal rights.
3. Purchaser acknowledges receipt of a fully completed copy of this contract and Purchaser waives notice of the acceptance or rejection of this order by the seller.
4. The additional terms and conditions set forth on the reverse side are a part of this contract and are incorporated herein by reference.
5. Seller retains a security interest in the purchased goods until the price is fully paid.

Accepted for GROFF TRACTOR MID ATLANTIC, LLC

Purchased by: _____
Company Name

BY: _____ X: _____
Gross Tractor Mid Atlantic Signature Title Date Purchaser Signature Title Date

**Groff Tractor Mid Atlantic, LLC
Terms and Conditions**

1. PRICES: All Prices quoted herein are exclusive on and City, State or Federal taxes on manufacture, sales, use and the like. Whenever applicable, the buyer shall be solely responsible for payment thereof.

2. PAYMENT: Payments shall become due in accordance with the terms hereof. Finance charges are subject to rate approval by financial institutions. The terms of sale are subject to credit approval and seller may, at any time prior to delivery, modify the terms of payment originally specified to assure prompt payment for the equipment ordered.

3. SECURITY INTEREST: Seller shall retain a security interest in the equipment delivered hereunder until the total selling price, including taxes, delivery and other charges, is paid in full by buyer. Buyer agrees to sign and deliver to seller any additional security agreement required by seller. Buyer hereby appoints seller as buyer's agent to sign and cause to be filed on behalf of buyer any and all financing statements deemed necessary by seller to perfect the security interest granted by buyer to seller hereunder.

4. WARRANTY: Seller warrants each new product within the time period or hourly limitation established by the manufacturer thereof. Seller's sole obligation under this warranty shall be limited to repairing, replacing or allowing credit for, at seller's option, any part or component which under normal and proper use and maintenance proves defective in material or workmanship.

THIS WARRANTY IS IN LIEU OF ALL OTHER WARRANTIES, EXPRESSED OR IMPLIED AND THERE IS NO IMPLIED WARRANTY OF MERCHANTABILITY AND FITNESS FOR A PARTICULAR PURPOSE WHICH EXCEED THE AFORESTATED OBLIGATION ARE HEREBY DISCLAIMED BY SELLER AND EXCLUDED FROM THIS AGREEMENT, UNLESS OTHERWISE EXPRESSLY STATED ON THE FACE OF THIS FORM.

USED PRODUCTS ARE SOLD ON AN "AS IS" BASIS AND THERE IS NO IMPLIED WARRANTY OR MERCHANTABILITY OR OF FITNESS FOR A PARTICULAR PURPOSE, UNLESS OTHERWISE EXPRESSLY STATED ON THE FACE OF THIS FORM.

FURTHER, THERE ARE NO ORAL OR WRITTEN PROMISES, TERMS, CONDITIONS, REPRESENTATIVES OF QUALITY OR FITNESS FOR ANY PURPOSE OR WARRANTIES, EXPRESSED OR IMPLIED, CONCERNING THESE PRODUCTS, OTHER THAN THOSE CONTAINED HEREIN IN WRITING, IF ANY.

BUYER AGREES TO INDEMNIFY AND HOLD TO SELLER HARMLESS FROM AND AGAINST ALL LIABILITY AND EXPENSES BASED UPON DAMAGE TO PROPERTY OR INJURY TO, OR DEATH OF, ANY PERSON ARISING OUT OF OR ATTRIBUTABLE TO THE USE OF SAID MACHINERY.

5. DEFAULT AND REPOSESSION: If buyer shall default in the performance of any of the terms, covenants and conditions of this Agreement, seller may declare the full amount due and payable without notice or demand and may repossess the equipment. Buyer agrees to pay attorney's fees in the amount of twenty percent (20%) of the amount due and payable, together with any other expenses incurred. Buyer shall be responsible for any expenses incurred by seller or its agents repossessing any item of equipment.

6. DELAYS: Seller may not be liable for loss or damage due to delay in delivery, resulting from any cause beyond seller's reasonable control including, but not limited to, acts of God, acts of omissions of the buyer, acts of civil or military authority, fires, strikes, factory shutdowns or alterations, embargos, war, riot or delay in transportation.

7. INSURANCE: The buyer shall at his own expense, but in the name for and in the benefit of the seller, insure said equipment against loss that may occur or be caused by fire, flood, explosion, theft or otherwise and liability of any and every kind until the selling price is paid in full by the buyer.

8. CANCELLATION: Buyer may cancel its order, reduce quantities, revise specifications or extend schedules only by mutual agreement as to reasonable and proper cancellation charges which shall take into account expenses already incurred and commitments made by the seller against any loss resulting there from.

INITIALS